

# TRANSEFLUID

**trasmissioni industriali**

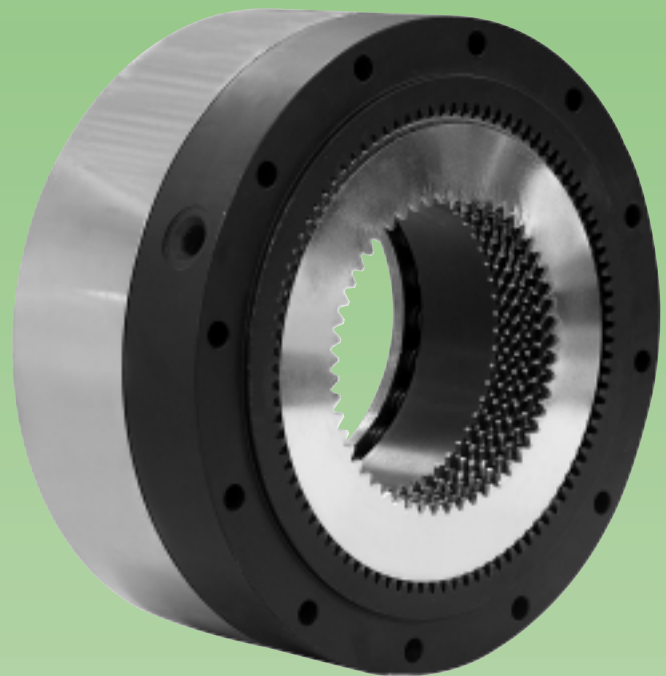

TRANSEFLUID



**drive with us**

**SL**  
SPRING LOADED BRAKES

# SL SPRING LOADED BRAKES

## OPERATION

The spring loaded SL brakes are designed for all applications where a fail safe brake is required. The brake consists of an hydraulic assembly, a plate assembly and a driven hub which can be supplied by TRANSFLUID upon request or can be manufactured by Customer.

SL brake is a hydro-mechanical device which is Spring Loaded and hydraulically released.

A spring load exerts a compressive force between steel plates, which are mounted on the rotating shaft, and sintered plates mounted in the gear tooth ring.

When oil pressure is applied, the spring load is relieved and the plates are free to move axially on the shaft hub allowing free rotation of the shaft. The brake is re-applied by dumping the oil pressure.

## BRAKE SELECTION

Applications, where the brake is used to stop low inertia loads, can be handled with a brake having a torque rating equal to the full load torque of the motor. In this case use the formula:

$$T_s = \frac{N \cdot 9550}{\text{rpm}}$$

Where:  $T_s$  = brake static torque in Nm

$N$  = motor power in kW

rpm = brake shaft speed

To brake high inertia loads, or when operating conditions are particularly severe, we suggest the following formula is used to select the brake:

$$T_d = \frac{GD^2 \cdot \text{rpm}}{38.2 \cdot t}$$

Where:  $T_d$  = brake dynamic torque in Nm

$GD^2$  = inertia reduced to brake shaft  $\text{Kg}\cdot\text{m}^2$ .

rpm = brake shaft speed

$t$  = braking time in sec.

The correct brake can be selected by using the above mentioned formula but our technical department will be pleased to make the selection for you.

## LUBRICATION

Use SAE 10 W oil.

Model	Static torque $T_s$ (Nm)	Dynamic Torque $T_d$ (Nm)					Release pressure (bar)
		Torque at zero rpm	Torque	rpm	Torque	rpm	
<b>SL 630 (12E)</b>	187	160	125	1000	93	2000	11.5
<b>SL 630</b>	230	198	153	1000	115	2000	14
<b>SL 640 (18E)</b>	430	370	290	1000	220	2000	14
<b>SL 640</b>	540	463	365	1000	280	2000	17
<b>SL 450</b>	670	580	450	850	338	1700	24
<b>SL 750</b>	1180	1020	795	850	593	1700	24
<b>SL 760</b>	1800	1550	1200	750	900	1500	21.3
<b>SL 960</b>	2320	1990	1555	750	1160	1500	21.3
<b>SL 770</b>	3180	2730	2130	650	1590	1300	24.2
<b>SL 970</b>	4090	3510	2730	650	2045	1300	24.2
<b>SL 780</b>	4570	3920	3060	550	2285	1100	23.3
<b>SL 980</b>	5870	5040	3930	550	2940	1100	23.3
<b>SL 790</b>	6860	5560	2840	475	2840	950	24
<b>SL 990</b>	8830	7160	3630	475	3630	950	24

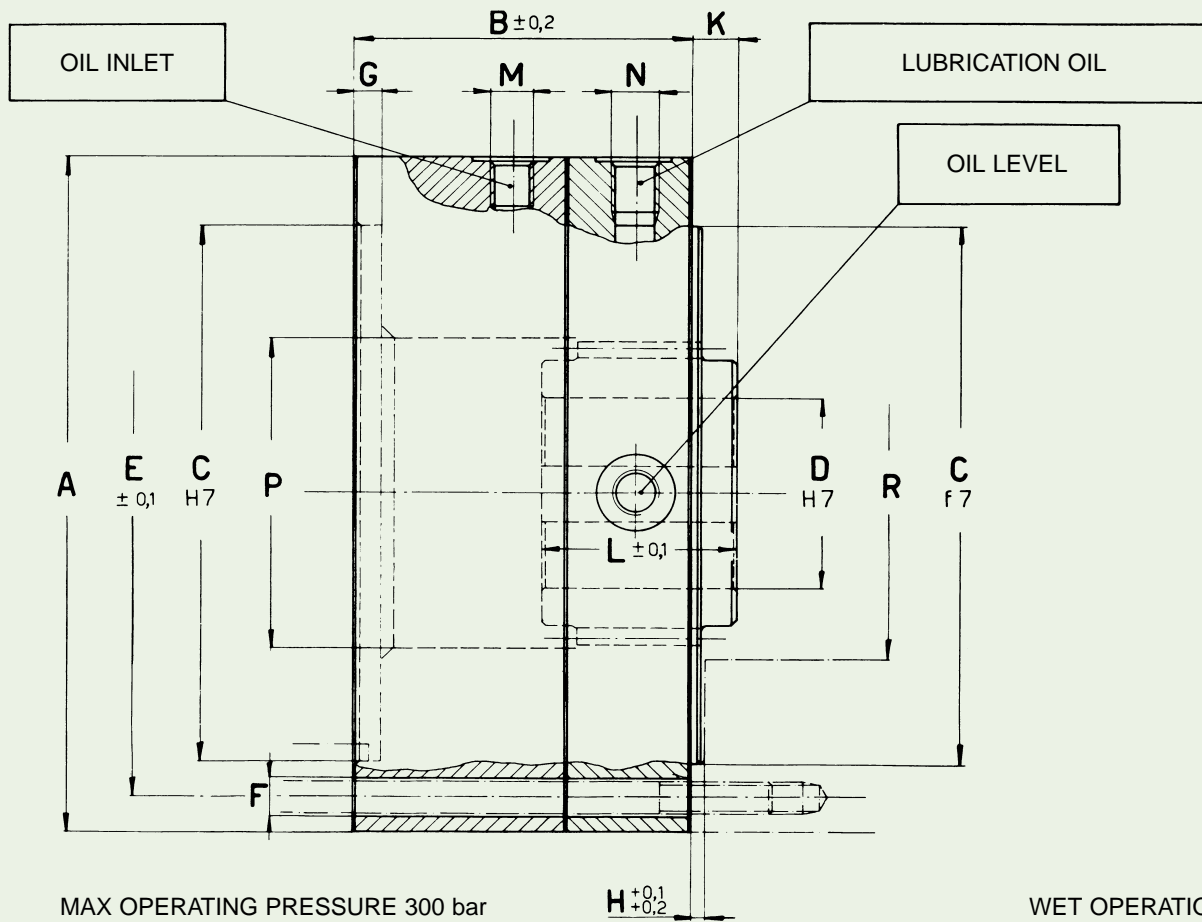

Model	DWG	A	B	C	D		E	F		G	H	K	L	M	N (BSP)	P	R	Weight kg (w/o oil)
					Min	Max		Dia	Nr									
<b>SL 630</b>	A 6708	129	72.5	100	18	30	115	8.5	8	4	2.5	3	32	1/8 BSP	1/8	40.5	63.5	7
<b>SL 640</b>	A 6100	159	65	130	20	42	145	8.5	12	5	3	8	40	M10x1	1/4	70	81.5	8.5
<b>SL 450</b>	A 5975-A	195	79	155	25	55	175	10.5	8	7.5	3	13	42	M12x1.5	1/4	90	101.5	11.5
<b>SL 750</b>	A 5975	195	90	155	25	55	175	10.5	8	7.5	3	13	55	M12x1.5	1/4	90	101.5	13
<b>SL 760</b>	A 5601	225	95.8	180	30	65	205	10.5	8	7.5	3	18	65	M12x1.5	1/4	103	103	18
<b>SL 960</b>	A 5601-A	225	105	180	30	65	205	10.5	8	7.5	3	18	75	M12x1.5	1/4	103	103	20
<b>SL 770</b>	A 5602	255	112	210	35	75	235	12.5	8	9.5	3	17.5	70	M14x1.5	3/8	118	118	27.2
<b>SL 970</b>	A 5602-A	255	122.5	210	35	75	235	12.5	8	9.5	3	17.5	80	M14x1.5	3/8	118	118	29.5
<b>SL 780</b>	A 5618	295	115	240	40	90	270	12.5	8	9.5	3	27.5	90	M14x1.5	3/8	143	151	36
<b>SL 980</b>	A 5618-A	295	125.5	240	40	90	270	12.5	8	9.5	3	27.5	100	M14x1.5	3/8	143	151	39
<b>SL 790</b>	A 5619	328	137	270	50	110	302	12.5	12	12.5	4	33.5	110	M14x1.5	3/8	162	182	52.2
<b>SL 990</b>	A 5619-B	328	150	270	50	110	302	12.5	12	12.5	4	33.5	123	M14x1.5	3/8	162	182	59.2

## ASSEMBLY

- 1 - Fit hub A onto the shaft.
- 2 - Mount gasket B and gear tooth ring C on the frame of the machine.
- 3 - Insert the plates as follows: sintered plate D, steel plate E and so on: the complete pack should end with a sintered plate D.
- 4 - Mount gasket F, hydraulic assembly G, gasket H and end plate K.

- 5 - Tighten screws L up to a particular locking torque.
- 6 - Close outlet hole by plug M (supplied by Customer).
- 7 - Fill with oil the plate group up to the level hole which must then be closed by plug N (supplied by Customer). Close filling hole by plug P (supplied by Customer).
- 8 - Connect the hydraulic assembly to the hydraulic circuit with pipe Q (supplied by Customer).

Through shaft mounting

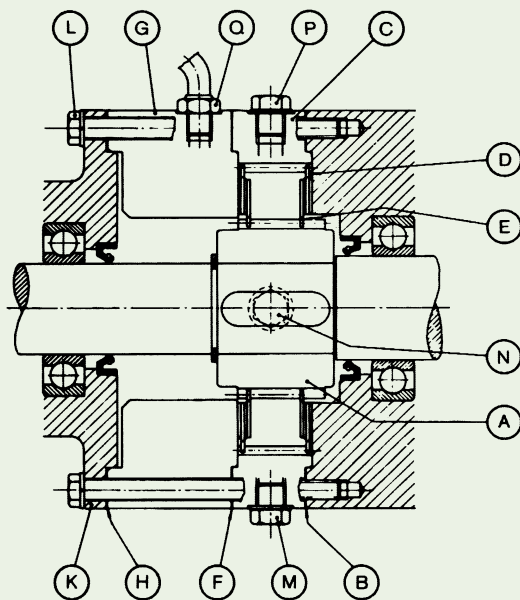

Outboard mounting

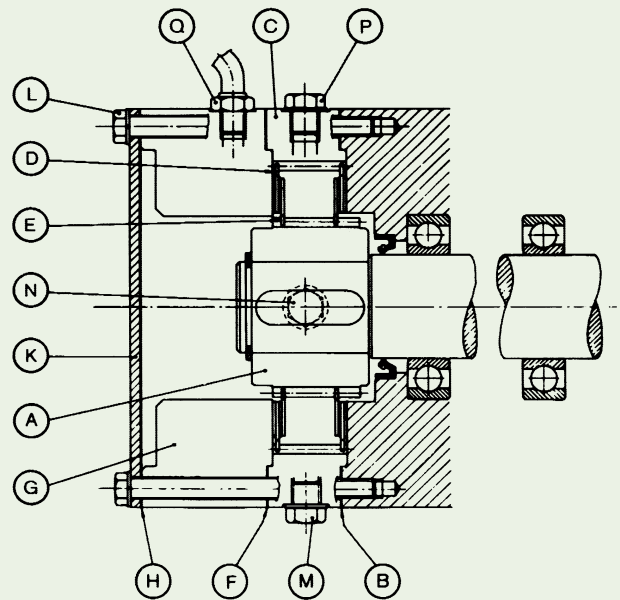

## HYDROSTATIC TRANSMISSIONS APPLICATIONS

Open circuit hydraulic diagram

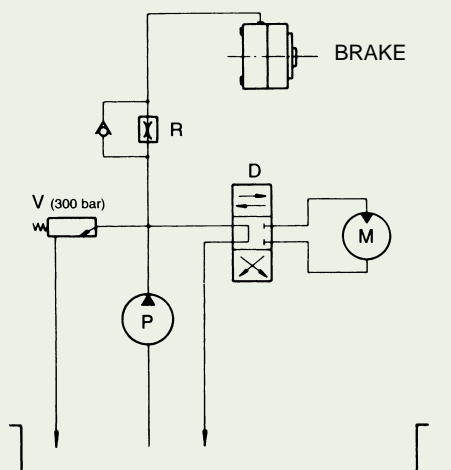

P = Pump  
 D = Control valve  
 M = Hydraulic motor  
 R = Retarder  
 V = Max pressure valve

Closed circuit hydraulic diagram

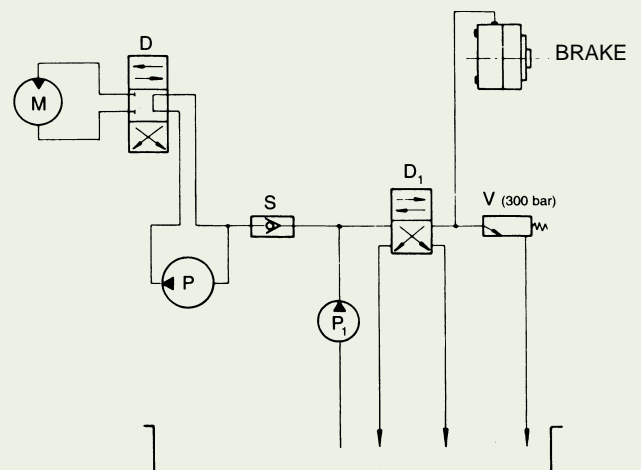

P<sub>1</sub> = Charging pump  
 D<sub>1</sub> = Brake control valve  
 S = One way valve