

TRANSFLUID

trasmissioni industriali

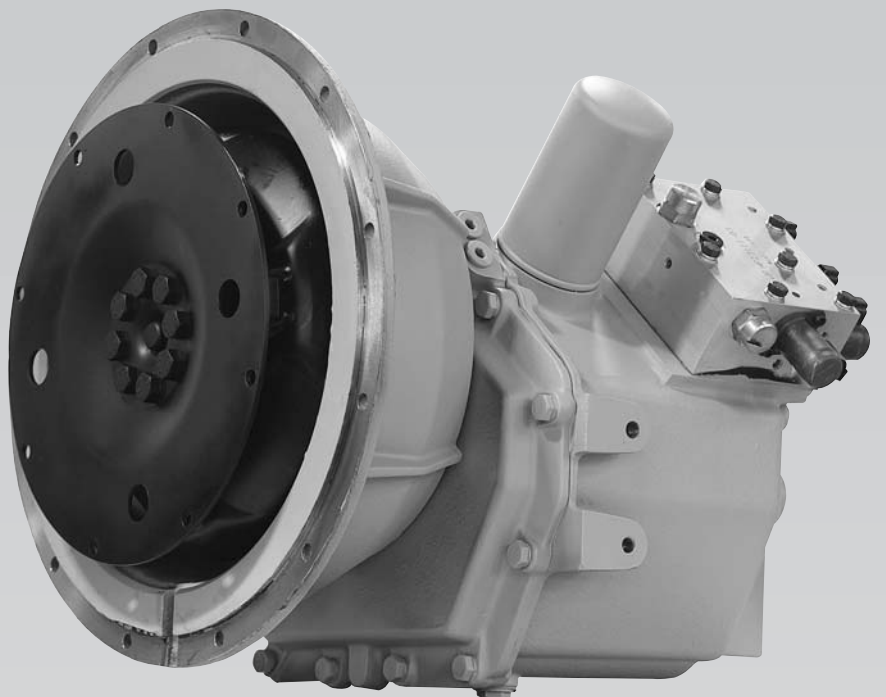

drive with us

RANGERMATIC POWER SHIFT
TRANSMISSION

RANGERMATIC is a three or two speed forward and one speed reverse (version 31-700 or 21-700), or two speed bidirectional (version 22-700), countershaft drop Power Shift Transmission, expressly studied for industrial applications requiring the ability of quickly and smoothly inverting direction and changing speed.

It basically consists of a double gear train, actuated by self contained hydraulic clutches and connected to the engine flywheel through a single stage hydrodynamic Torque Converter, the capacity of which is selected according the engine rating and the application.

Through the Torque Converter all mechanical connection with the engine is eliminated and power is smoothly transmitted.

TECHNICAL DATA

- Nominal rating:
- max input speed
- single stage, 2 phase Torque Converter
- engine flywheel housing SAE J 617
- engine flywheel SAE J 620
- output flange for universal joint
- gear ratios:
version 31-700
version 21-700
version 22-700
- operating pressures:
clutches
cooler
- dry weight:
version 31-700
version 21-700
version 22-700
- oil capacity

It is provided with an output flange for universal joint mounting.

The hydraulic clutches are operated by a hydraulic selector, electrically actuated, including, as standard equipment, a "soft shift" device.

The hydraulic system has an integrated oil gear pump, driven by the engine and a filter assuring a total oil filtration.

The pump feeds the torque converter, the clutches, the cooling and lubrication systems.

70 kW off road } **all applications must**
95 kW on road } **be approved**
2800 rpm }

W 280

SAE 3 or 4
10" standard
DIN 120 standard

Fwd = 2.75 - 1.882 - 0.865	Rev. = 1.882
Fwd = 1.882 - 0.865	Rev. = 1.882
Fwd = 1.882 - 0.865	Rev. = 1.882 - 0.865

14 bar
2 - 3 bar

123 kg
117 kg
120 kg

7 litres

APPLICATIONS:

- material handling machines, shop and off road vehicles
- earth moving machines:
front loaders, back-hoe loaders, dumpers
- industrial and airport tractors
- mobile cranes
- concrete mixers
- shunt locomotives and rail vehicles
- forest and mining vehicles
- utility vehicles

