

TRANSFLUID

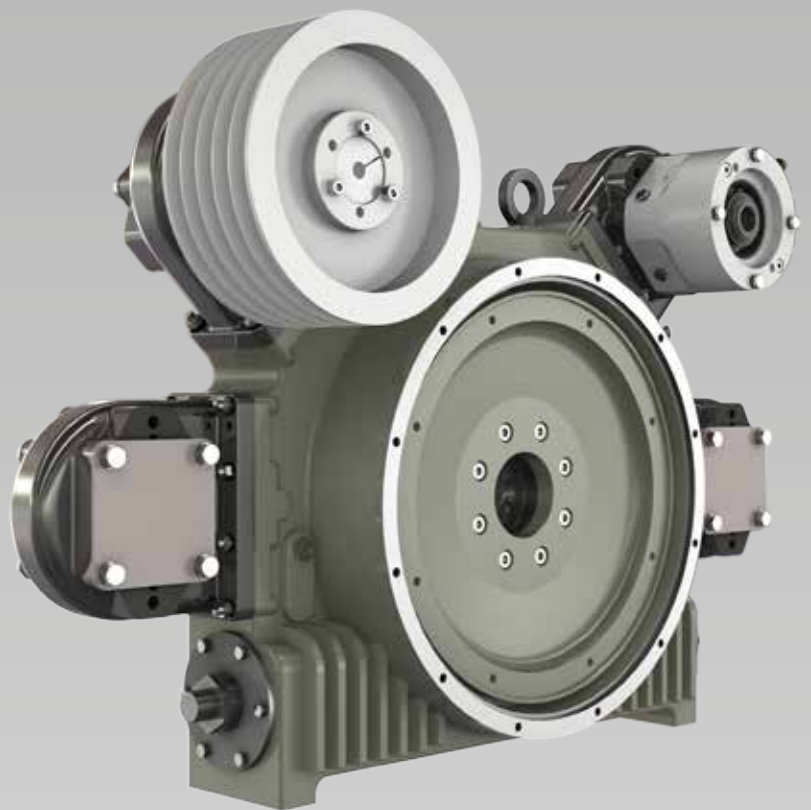

TRANSFLUID

trasmissioni industriali



drive with us

STELLADRIVE

MPD-MULTI PUMP DRIVE

The MPD STELLADRIVE is an innovative module that fits between an engine and a transmission to drive a multiple hydraulic pumps.

The MPD mounts directly to the engine SAE housing and flywheel and uses an integrated flexible coupling to dampen torsional vibrations and compensate for misalignment.

The output is a SAE dummy flywheel and housing that connects to any SAE driven equipment such as marine transmissions or PTOs like Transfluid's HFO/HFR/HFF (oil/air actuated PTO), KPTO (fluid coupling) and PF-PTO (PTO with RBD rubber coupling).

The units are self-contained with their own lubrication circuit.

Foot mounted designs are available. In case of installation on the output side of devices having an elastic coupling, Transfluid requires full information about it in order to check the torsional compatibility of the system.

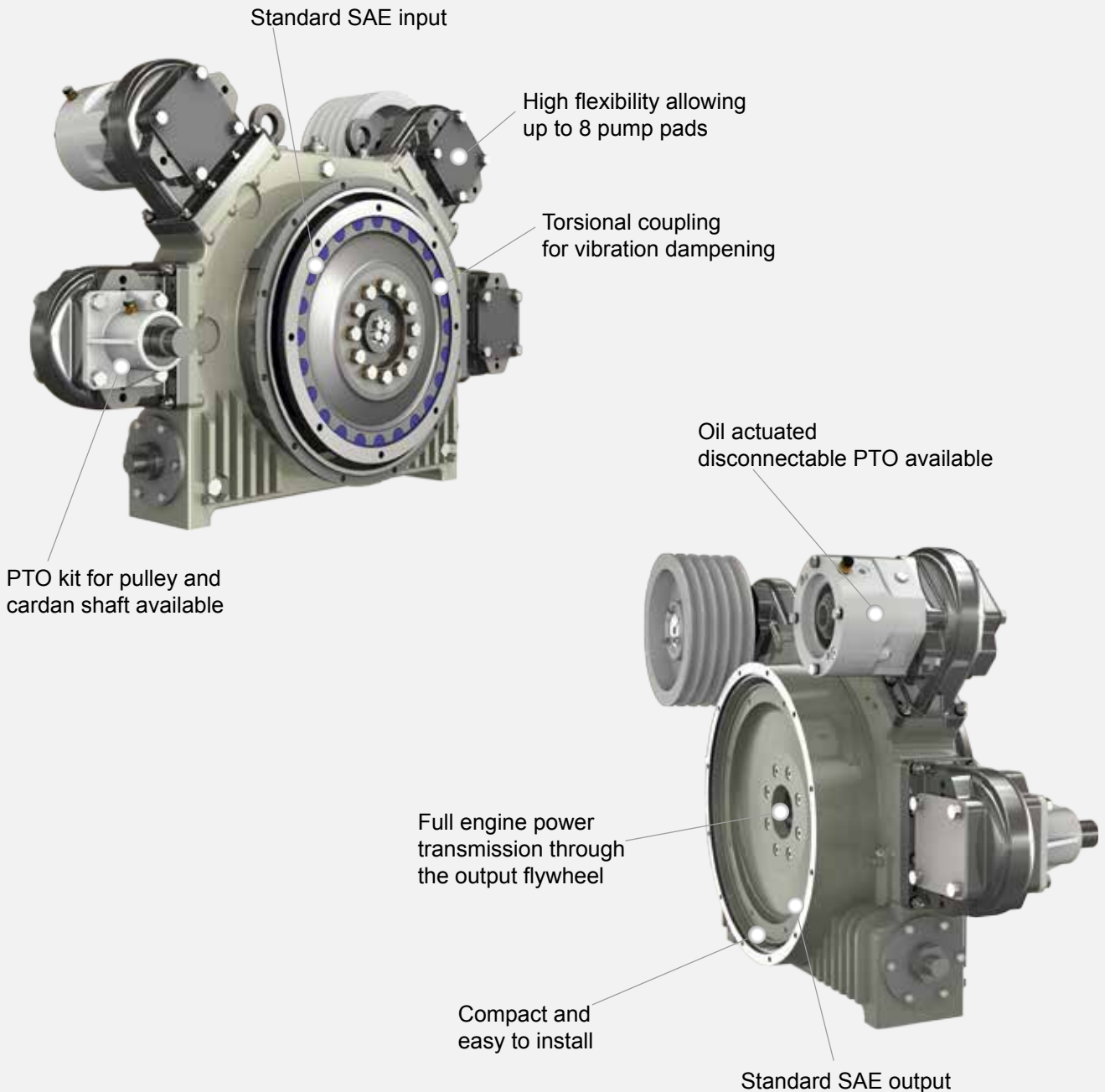

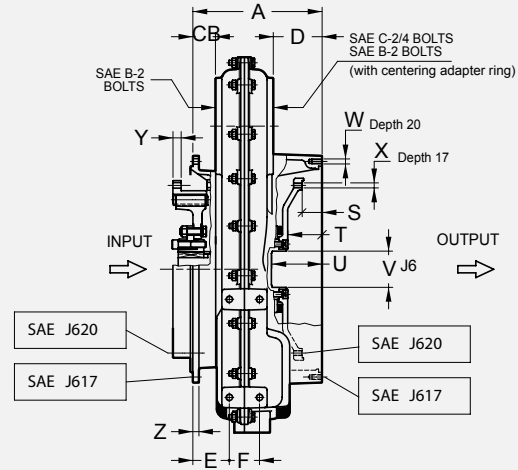
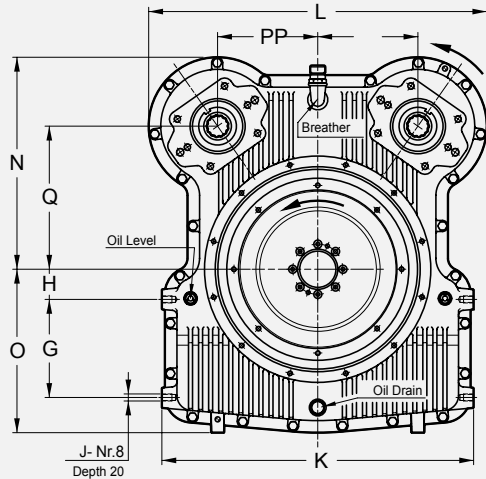

MPD14

DIMENSIONS

Size	INPUT		OUTPUT		A	B	C	D	E	F	G	H	J	K	L	N	O	P	Q	S	T	U	V	W		X		Y	Z		
	SAE J617	SAE J620	SAE J617	SAE J620																				Ø	N°	Ø	N°				
14	3	11½"	3	11½"	257	115	45	97	72.5	60	195	60	M14	620	673	422	325	199.2	284.5	39.6	68.1	100	72	M10	12	M10	8	52	12		
	1	14"			282		70		97.5																						

TECHNICAL DATA

Size	Weight w/o oil kg	Oil Quantity l	Max speed rpm	Max Input torque Nm	Total Heads kW	Single Head kW	Ratio (n1:n2)
14	195	12.5	2600	2000	175	120	1.0

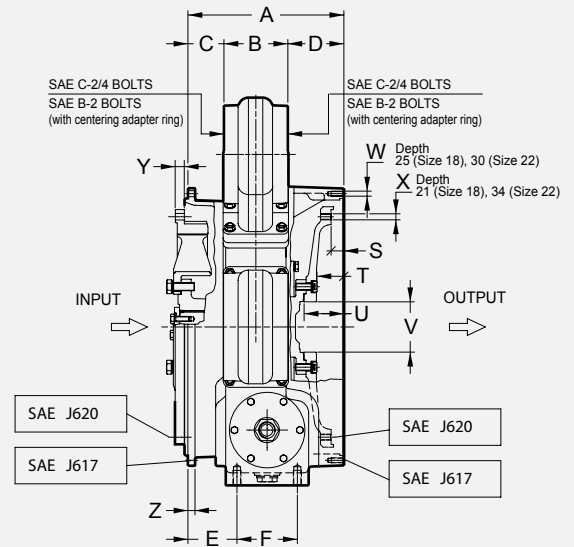
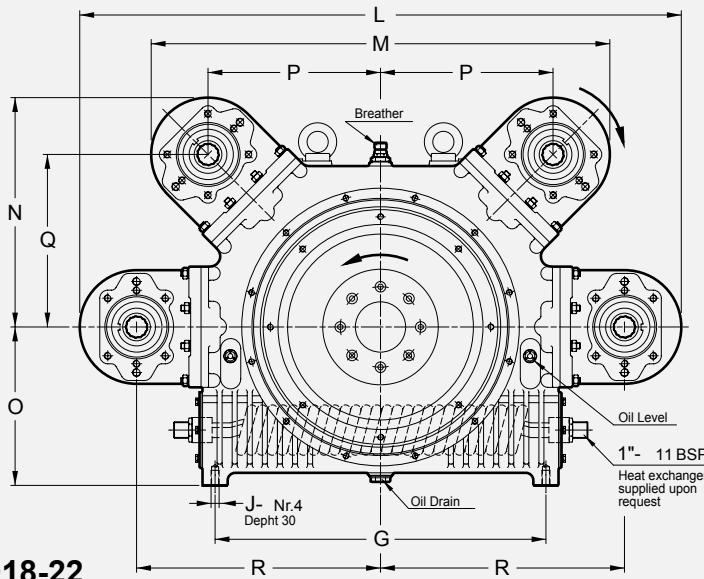

MPD18-22

DIMENSIONS

Size	INPUT		OUTPUT		A	B	C	D	E	F	G	J	L	M	N	O	P	Q	R	S	T	U	V	W		X		Y	Z
	SAE J617	SAE J620	SAE J617	SAE J620																				Ø	N°	Ø	N°		
18	1	14"	1	14"	310	127	71.5	111.5	97.5	120	658	M16	1197	913	456.5	315	343	343	485.2	25.4	53.5	79	100	M10	12	M12	8	18	14
22	1	14"	0	18"	374		119	128	134	130	772	M18	1326	1004	502	415	388.7	388.7	549.7	15.7	48.2	81	150	M12	16	M16	6	85	15
	0	18"			363	108																							18

TECHNICAL DATA

Size	Weight w/o oil kg*	Oil Quantity l	Max speed rpm	Max Input torque Nm	Total Heads kW**	Single Head kW**	Ratio (n1:n2)
18	350	18	2200	3350	300	120	1.0 (0.88)
22	530	35	2100	6300	400	175	0.95

* deduct 20 kg for each head

** @ max. speed

*** not SAE standard

Dimensions are subject to alteration without notice

SPD - DUAL PUMP DRIVE

The SPD is an innovative modular pump drive designed to be mounted on industrial engines with SAE flywheels and housings.

The input is a rugged Rubber Block Drive flywheel coupling. This elastic coupling absorbs radial and angular misalignments as well as dampens torsional vibrations.

The SPD 11 output is a dual pad SAE A or B pump tower as well as SAE flywheel and flywheel housing.

To allow for easy installation the pump tower can be mounted in 12 possible positions over 360 degrees.

The output flywheel can accept transmissions, pumps, compressors and PTO's.

SPD 11

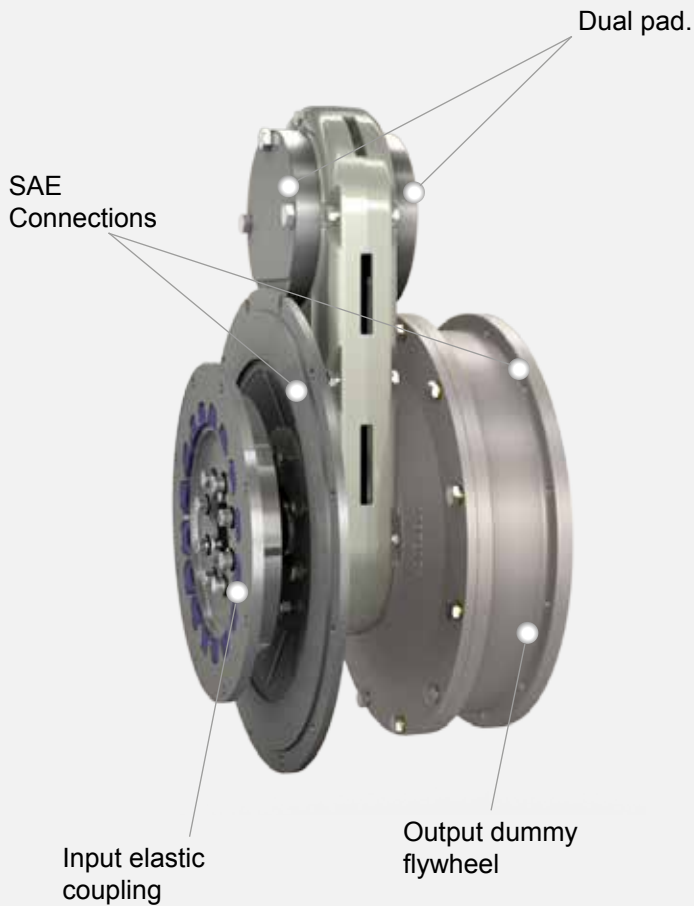

SPD 11S

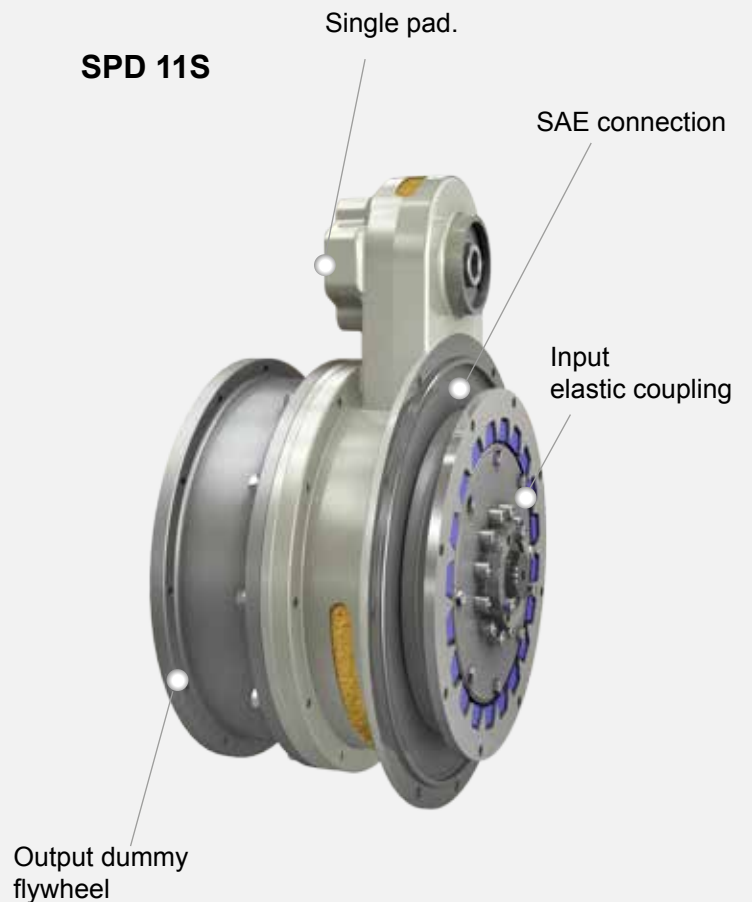

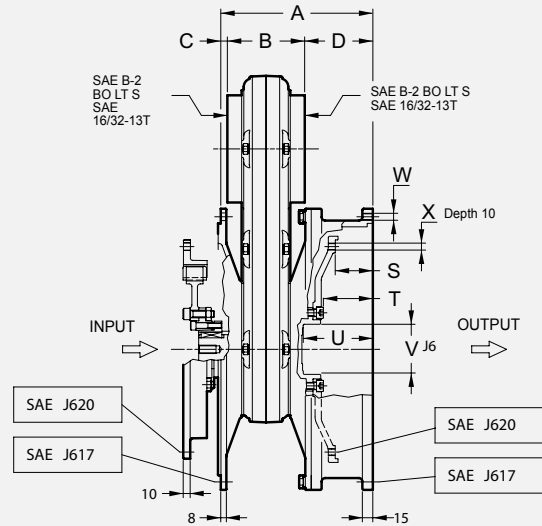
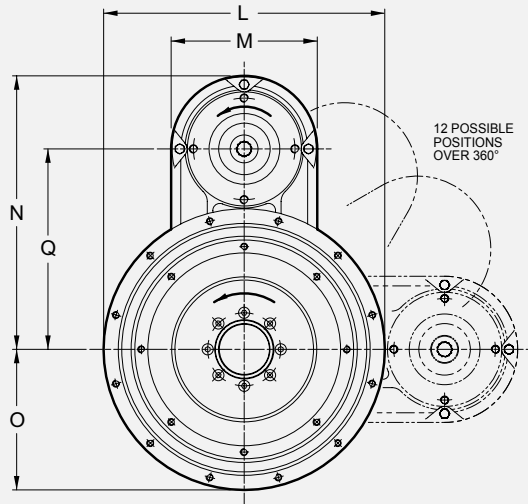

SPD 11

DIMENSIONS																		
Size	INPUT		OUTPUT		A	B	C	D	L			N	M	O			Q	S
	SAE J617	SAE J620	SAE J617	SAE J629					SAE 3	SAE 4	SAE 5			SAE 3	SAE 4	SAE 5		
11	3 4 5	11½ 10" 7½	4	10	218.5	111	9.5	98	451	404	356	393	210	225.5	202	178	288	53.8

DIMENSIONS								TECHNICAL DATA							
Size	T	U	V	W		Y		Weight kg	Max speed rpm	Max input torque Nm			Head kW*	Ratios (n1:n2)	
				∅	N°	∅	N°			SAE 3	SAE 4	SAE 5			
11	71	100	72	M10	12	M10	8	50	3000	560	560	310	53	1.0	

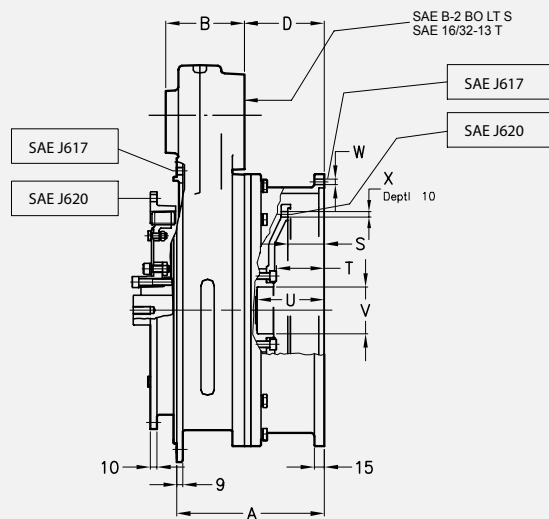
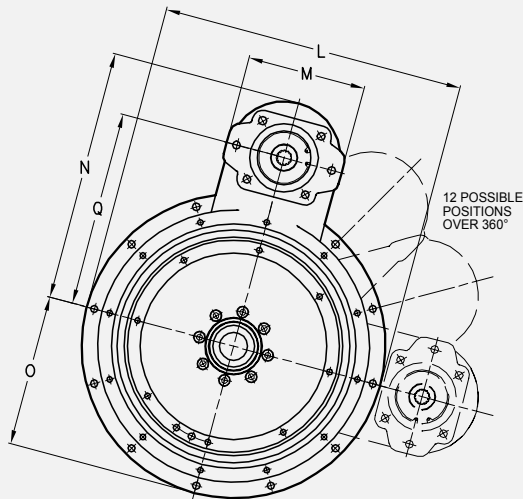

SPD 11S

DIMENSIONS													
Size	INPUT		OUTPUT		A	B	D	L	M	N	O	Q	S
	SAE J617	SAE J620	SAE J617	SAE J620									
11S	3 4	11½ 10"	4	10"	219	117	119	452	177	374	226	290	54

DIMENSIONS								TECHNICAL DATA					
Size	T	U	V	W		X		Weight kg	Max speed rpm	Max input torque Nm		Head kW*	Ratios (n1:n2)
				∅	N°	∅	N°			SAE 3	SAE 4		
11S	71	100	72	M10	12	M10	8	85	3000	860	560	110	0.93

* @ 3000 rpm

Dimensions are subject to alteration without notice

Head extension for MPD18 and 22 only

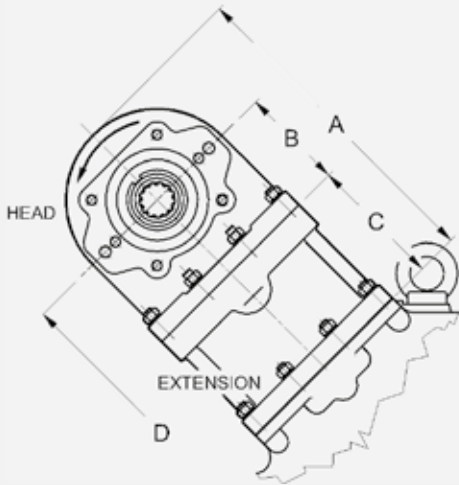

DIMENSIONS				
	A	B	C	D
MPD18	405	128	164	649
MPD22	431	128	190	740

*from main shaft axis

When there is interference between the pumps mounted on the MPD and the driven device, the head extension kit is the perfect solution. This kit mounts on any head and provides an extra 164 mm of clearance for MPD18 and 190 mm for MPD22. Additionally, the extension kit reverses the rotation of MPD head making it useful where engine rotation is required.

Air/oil actuated clutches for pump disconnection

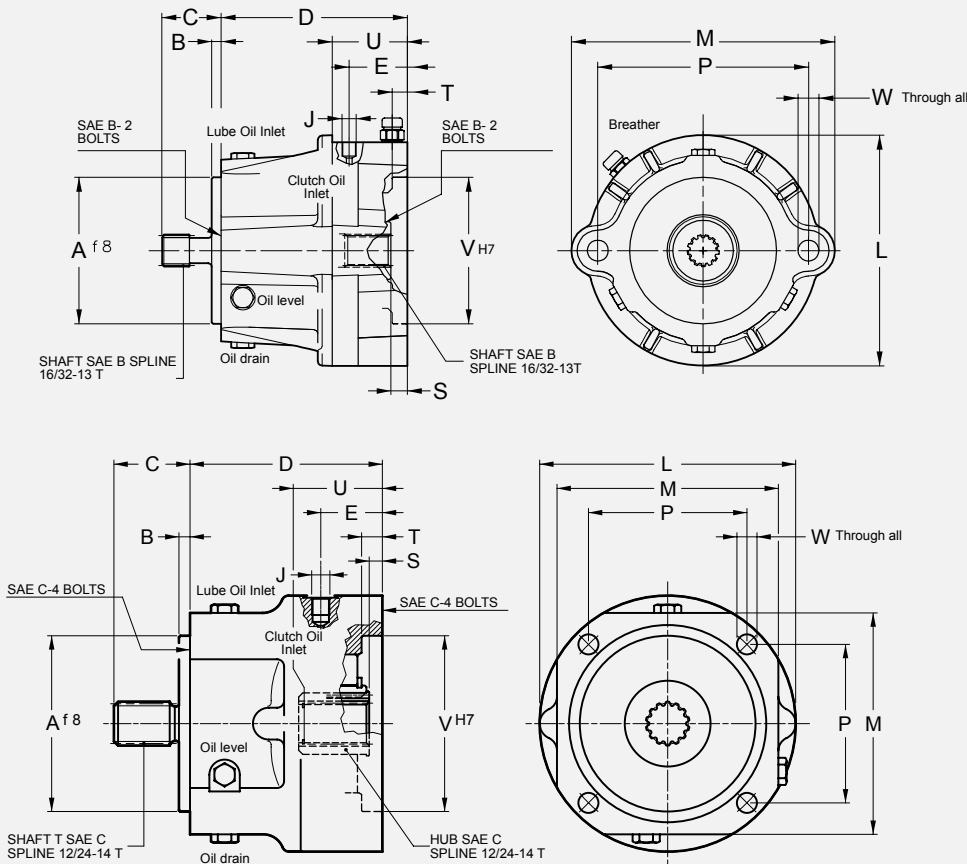

BB640	Working pressure bar	5	7	9
	Max torque Nm	140	195	250
CC650	Working pressure bar	5	7	9
	Max torque Nm	280	390	500

Size	DIMENSIONS														TECHNICAL DATA				
	A	B	C	D	E	J	L	M	P	S	T	U	V	W		Max torque Nm	Max pressure bar	Weight w/o oil kg	Oil Quantity l
	Dia.	N°																	
BB640	101.6	6.5	41	129	41.5	1/8" BSP	168	190	146	11.5	10.5	52	101.6	14.5	2	340	12	15	1.6
CC650	127	8	55	139	44.5	1/4" BSP	185	160	114.5	9.5	15	56.5	127	14.5	4	830	15	16.5	1.8

Dimensions are subject to alteration without notice

Head PTO for in-line and pulley mounting

TECHNICAL DATA					
PTO	Max speed rpm	Max torque Nm	Max side Load N with X=24	Weight w/o oil kg	Oil Quantity l
SAE B	3000	140	7200	6	0.05
SAE C	3000	500	7200	7	0.05

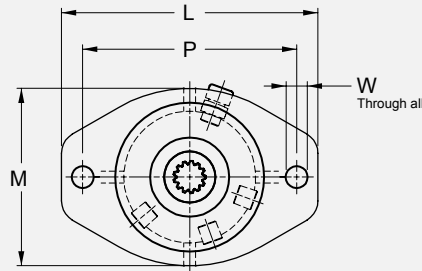
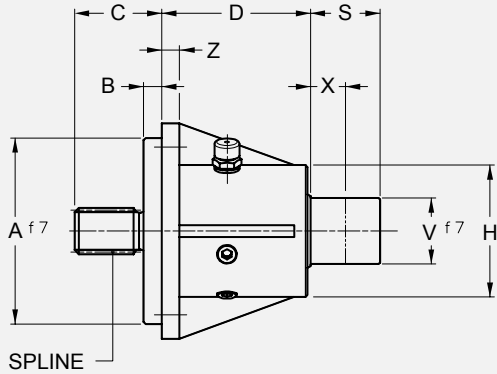

SAE B - 2 HOLES

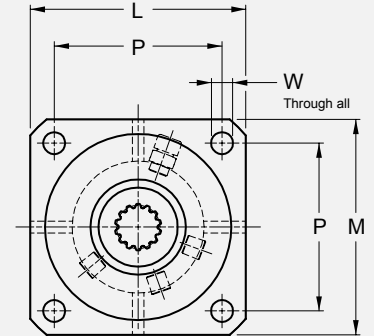

SAE C - 4 HOLES

DIMENSIONS														
PTO	SPLINE SAE J744	A	B	C	D	H	L	M	P	S	V	W		Z
												Dia.	N°	
SAE B	13T 16/32	101.6	9	41	101.5	90	175	121	146	47.5	45	15	2	12
SAE C	14T 12/24	127	12.5	55	101.5	90	147	147	114.5	47.5	45	15	4	12

SU free standing
(without pilot bearing)



SU1

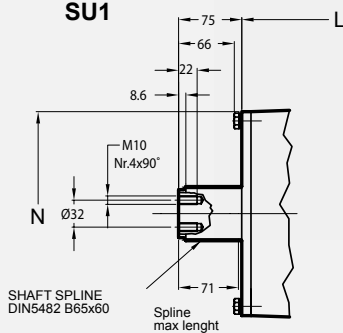

SU4 - SU3

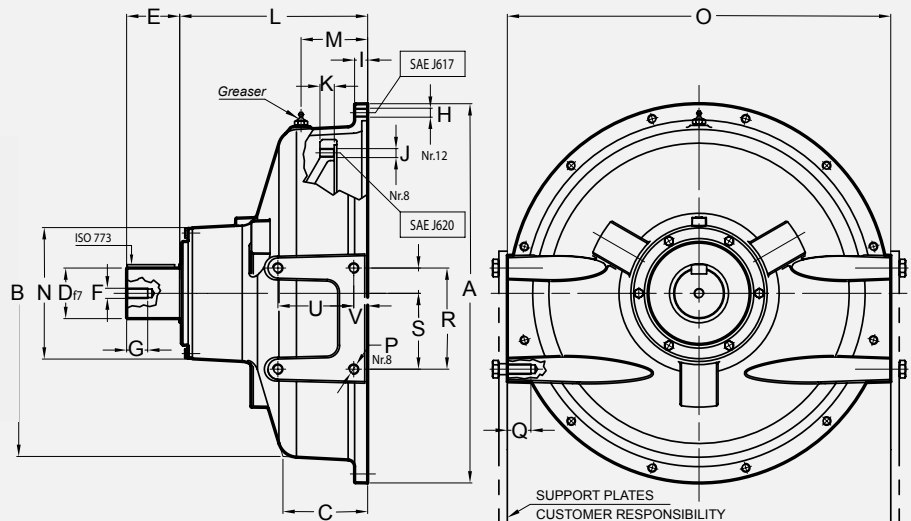

DIMENSIONS																								
Size	SAE J617	SAE J620	A	B	C	D	E	F	G	H	I	J	K	L	M	N	O	P	Q	R	S	T	U	V
SU4	4	10"	403	350	105	42	48	M12	25	M10	15	M10	-	201.5	-	138	405	M10	28	105	80	25	85	15
SU3	3	11½"	450	390	100	60	63	M12	25	M10	15.5	M10	78	223	78	156	455	M12	28	120	90	30	90	16.5
SU1	1	14"	552	500	143	See drawing				M10	23	M10	96	251	120	242	555	M16	35	240	120	120	130	25

Dimensions are subject to alteration without notice

MPD with HFO OIL ACTUATED PTO



SPD with HFR OIL ACTUATED PTO



MPD with KPTO VARIABLE FILL FLUID COUPLING



MPD with RANGERMATIC POWER SHIFT TRANSMISSION



MPD with MARINE GEAR



MPD with INPUT and OUTPUT CARDAN SHAFT (FOOT MOUNTING)

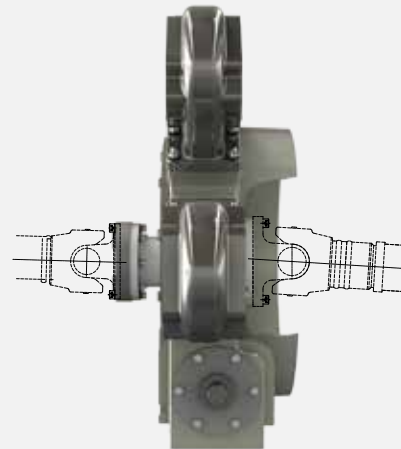

CHINA
TRANSFLUID BEIJING TRADE CO.LTD
101300 Beijing
Ph. +86.1060442301-2
Fax +86.1060442305
tbtcinfo@sina.com

FRANCE
TRANSFLUID FRANCE s.a.r.l.
38110 Rochetoirin
Ph. +33.9.75635310
Fax +33.4.26007959
tfFrance@transfluid.it

GERMANY
TRANSFLUID GERMANY GmbH
D-48529 Nordhorn
Ph. +49.5921.7288808
Fax +49.5921.7288809
tfGermany@transfluid.it

RUSSIA
TRANSFLUID OOO
143100 Moscow
Ph. +7.495.7782042
Mob. +7.926.8167357
tfrussia@transfluid.it

U.S.A.
TRANSFLUID LLC
Auburn, GA 30011
Ph. +1.770.8221.777
Fax +1.770.8221.774
tfusa@transfluid.it

Global web site: www.transfluid.eu • E-commerce web site: www.buy-transfluid.com