

TRANSFLUID



TRANSFLUID[®]

industrial & marine



drive with us

KPT
VARIABLE FILL FLUID COUPLINGS

FLUID COUPLINGS KPT SERIES

DESCRIPTION

The KPT is a variable fill fluid coupling designed to be a start up drive or a variable speed drive.

The KPT has an externally driven oil feeding pump and a remote electrically operated ON-OFF valve. When the valve is turned ON, the fluid coupling circuit is fed, when it is turned OFF, rapid oil drain occurs through orifices located on the periphery of the coupling.

The forced bearing lubrication is continuously assured.

The KPT control is achieved by on/off solenoid valve modulation or oil flow control valve (4-20mA signal) to obtain more accurate start up control and/or speed variation.

The KPT range is suitable for powers up to 1700 kW as start up drive and 600 kW as variable speed drive.

The input and output straight shafts can be connected to electric motor diesel/engine and driven machine by elastic and flexible couplings.

Standard accessories: oil motor pump, oil filter with pressure and temperature gauges, ON-OFF electric valve, oil temperature and pressure switches, oil level indicators, connecting wiring box with plug.

Optionals: oil flow control valve water or air heat exchanger, quick release valves, output pulley, flexible and elastic couplings, cardan shafts, electric control board.

WORKING SCHEME

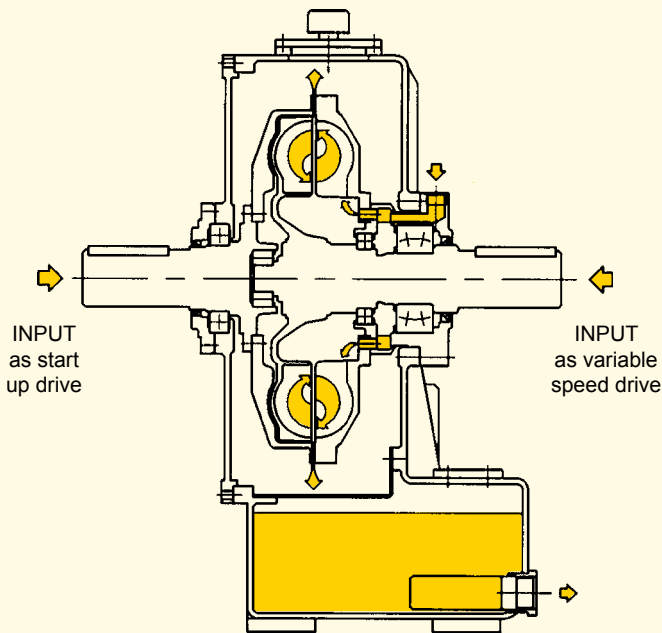

rpm	SELECTION TABLE (kW)					
	17	19	21	24	27	29
1000	-	70	100	150	220	350
1200	-	90	150	220	300	520
1500	-	160	230	315	570	1000
1800	-	275	400	545	1000	1700
3000	560	-				
3600	600					

FEATURES

The variable fill fluid coupling allows to disconnect the prime mover from the load, granting the following advantages:

- motor start up at no load
- smooth start up even possible under nominal motor current
- shock and overload protection
- torsional vibration dampening
- high radial load capacity (KPTe)
- no belt slip
- remote control
- load positioning
- cheap and easy maintenance due to external mounting of main accessories like oil filter, feeding pump, control valve
- longer life thanks to no friction linings to wear out
- accurate variable speed performances
- special hazardous area design available upon request

APPLICATIONS

start up drive:

- mills, crushers, wood chippers, grinders
- belt conveyors
- reciprocating and centrifugal pumps, compressors
- marine propulsion
- generators
- centrifuges, fans and blowers
- mixers

variable speed drives:

- centrifugal pumps and compressors
- fans and blowers
- mills, belt conveyors (inspection speed)

HYDRAULIC CIRCUIT

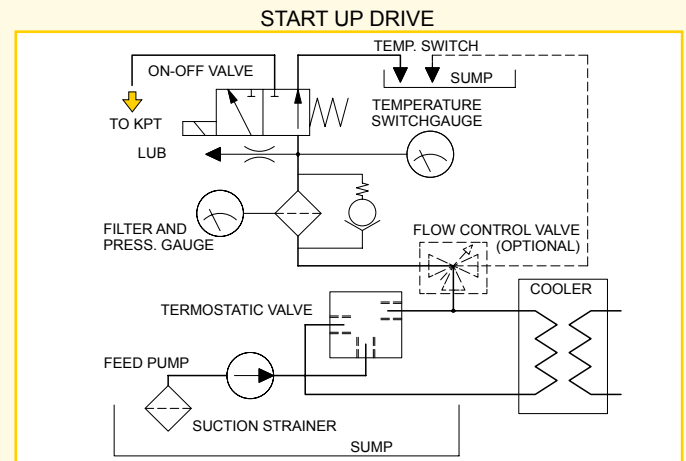
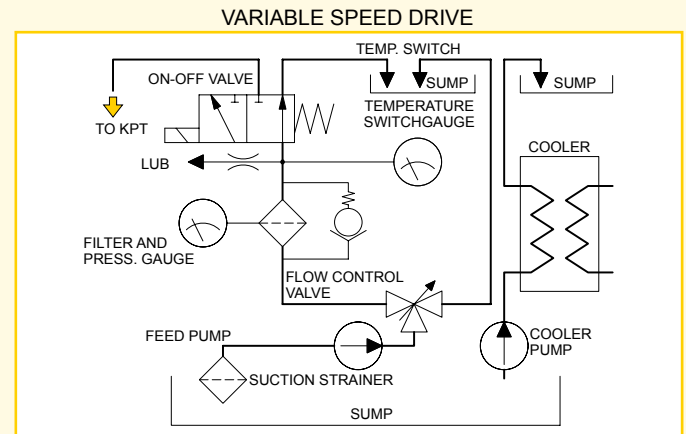

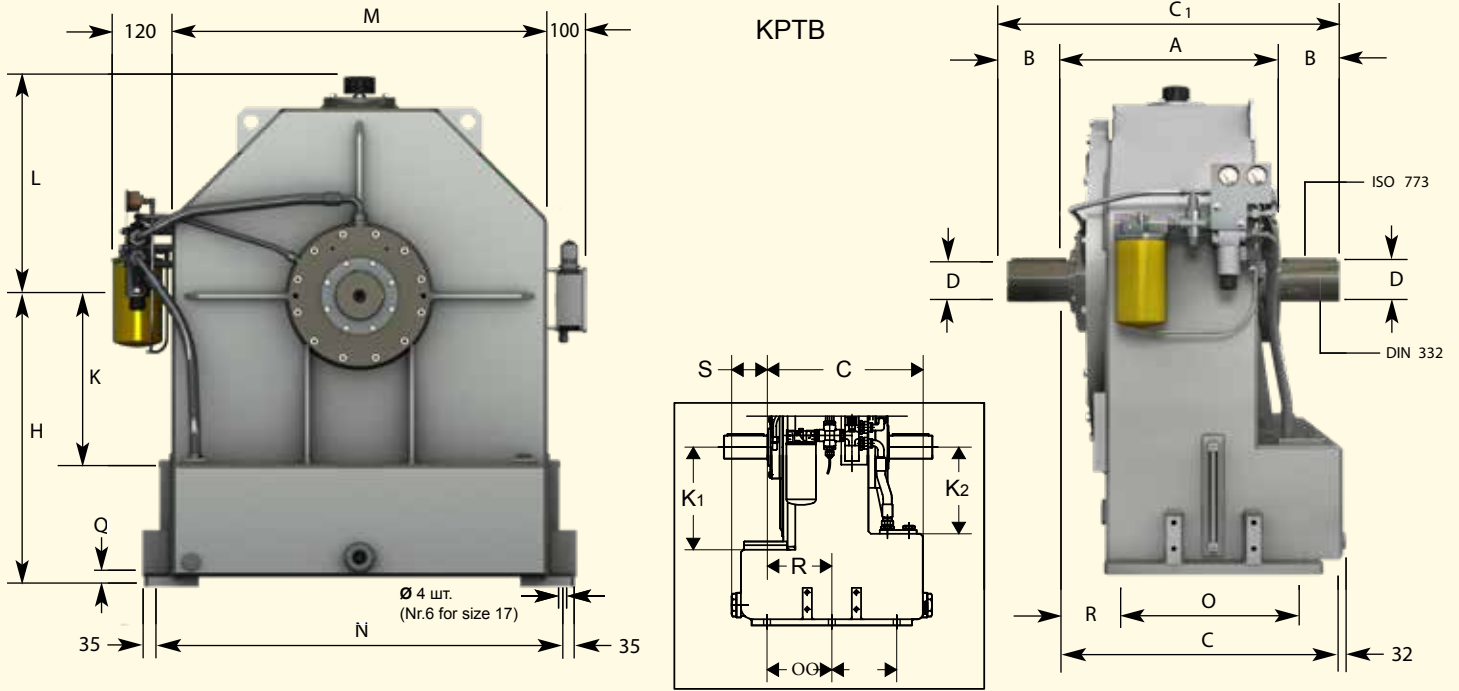

Only for 17 KPTB

Size ↕ Dimensions

Size	A	A ₁	B	B ₁	C	C ₁	C ₂	C ₃	C ₄	C ₅	D	D ₁	E	E ₁	G
15	390	402	110	130	502	610	836	772	723	613	65	70	90	76	75
17	396	406	120	150	506	636	864	798	750	640	75	80	110	76	95
19	396	406	120	150	506	636	864	798	750	640	75	80	110	76	95
21/24	451	463/539	140	180	586	731	1079	921	905	735	85	100	122	90	110
27	560	664	180	220	689	920	1270	1142	1095	925	100	115	145	105	120
29	610	-	180	-	739	970	1400	1192	1185	975	120	-	165	105	135

Size ↕ Dimensions

Size	G ₁	H	K	K ₁	K ₂	L	M	N	O	P	Q	R	S	Flexible coupling	Gear coupling	Weight (Kg) w/o oil	Oil (l)
15	85	520	282	-	-	420	670	730	228	22	20	137	-	B3M 48	2½"	280	40
17	85	580	-	334	282	420	670	730	211	22	20	210	116	B3M 55	2½"	305	85
19	85	520	282	-	-	420	670	730	280	22	20	141	-	B3M 55	2½"	500	40
21/24	100	625	350	-	-	487	820	880	325	26	25	146	-	B3M 60	3"	485/503	80
27	120	700	385	-	-	522	890	960	390	29	25	184	-	B3M 70	3½"	800	115
29	120	750	435	-	-	562	970	1040	440	29	25	184	-	B3M 80	3½"	1100	142

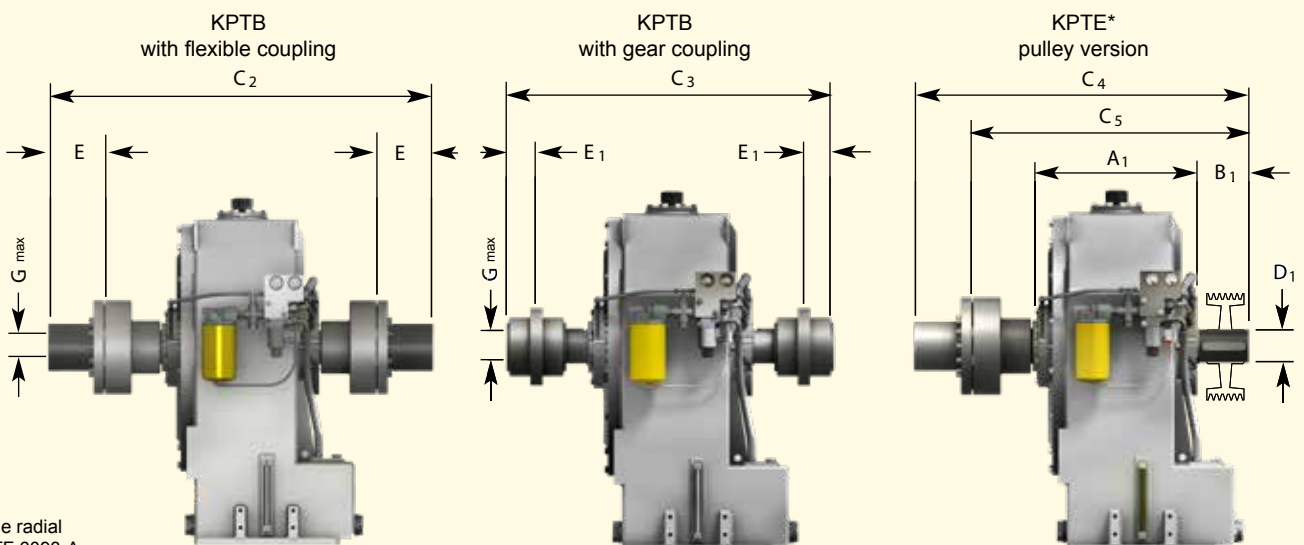

* For admissible radial loads refer to TF 6093-A

Dimensions can be changed without notice

Tables for the preliminary selection of the coolers:

- KPTB with single oil pump (with flow control valve if used as variable speed drive)
- Refer to variable speed drive or start up drive column
- Max power = max power absorbed at max speed
- Output water temperature 35°C

Variable speed application			
Fluid Coupling max. power (kW)	Water - Oil Cooler Model	Required Water Flow (l/min) at 25°C	Air - Oil Cooler Model (air = 30°C)
100	05048 •	31	TF7132AU
150	05048 •	47	TF7132AV
200	06060 • SP3-11 ••	62	TF7132AV
300	06060 • SP3-11 ••	94	TF7132AL
400	06096 • SP3-19 ••	125	TF7132AW
500	08084 • SP3-31 ••	157	TF7132AW
600	08084 • SP3-31 ••	188	TF7132AM

- Tube bundle heat exchanger
- Plate heat exchanger

Start-up application			
Fluid Coupling max. power (kW)	Water - Oil Cooler Model	Required Water Flow (l/min) at 25°C	Air - Oil Cooler Model (air = 30°C)
100	03014 •	8	TF7132AT
150	03024 •	11	TF7132AU
200	03024 •	15	TF7132AU
300	05024 •	23	TF7132AU
400	05048 •	31	TF7132AV
500	05048 •	39	TF7132AV
600	05048 •	47	TF7132AL
700	06060 • SP3-11 ••	55	TF7132AL
800	06060 • SP3-11 ••	62	TF7132AL
900	06060 • SP3-11 ••	70	TF7132AL
1000	06060 • SP3-11 ••	78	TF7132AW
1200	06060 • SP3-11 ••	94	TF7132AW
1400	06096 • SP3-19 ••	110	TF7132AW
1600	06096 • SP3-19 ••	125	TF7132AM

CHINA

TRANSFLUID BEIJING
TRADE CO. LTD Beijing
Ph.: +86.10.60442301-2
tbtcinfo@transfluid.cn

U.S.A.

TRANSFLUID LLC
Auburn, GA 30011
Ph.: +1.770-822-1777
tfusa@transfluid.us

FRANCE

TRANSFLUID s.a.r.l.
38110 Rochetoirin
Ph.: +33.9.75635310
tffrance@transfluid.eu

RUSSIA

TRANSFLUID OOO
Moscow
Ph. +7.495.7782042
tfrussia@transfluid.eu

THE NETHERLANDS

TRANSFLUID NORTH EUROPE
(Bellmarine)
NL-3992 AK, Houten
Ph. +31 (0)85 4868530
info@bellmarine.nl

LOCAL DISTRIBUTOR

Global web site:: www.transfluid.eu
E-commerce web site: www.buy-transfluid.com