

TRANSFLUID

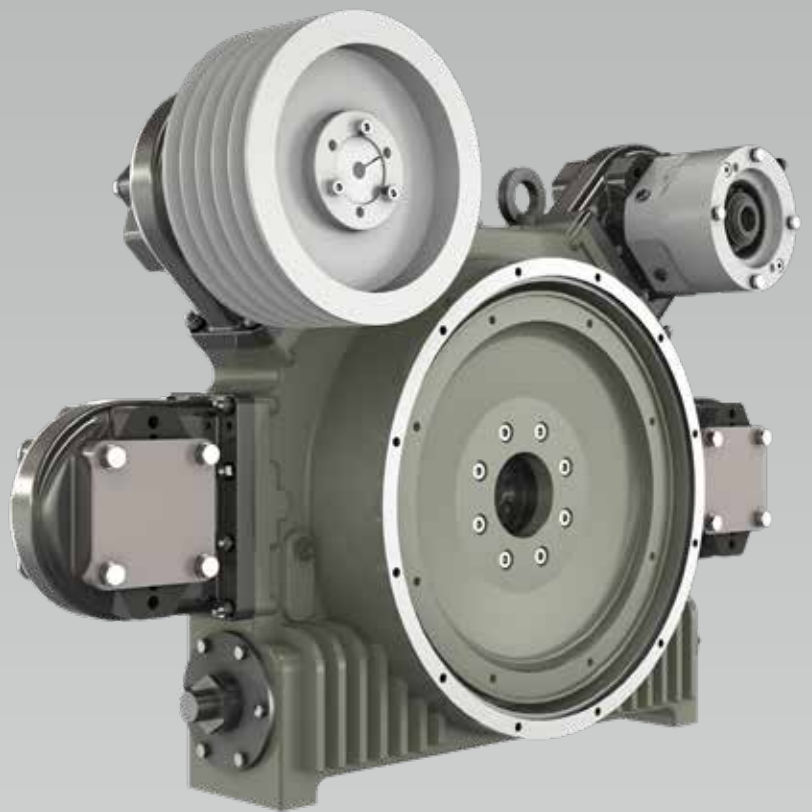

TRANSFLUID[®]
industrial & marine



drive with us

STELLADRIVE

MPD-MULTI POMPAANDRIJVING

De MPD STELLADRIVE is een innovatieve module die tussen een motor en een transmissie past om meerdere hydraulische pompen of andere geschikte apparaten aan te drijven.

De MPD wordt direct op de motor SAE-behuizing en vliegwiel gemonteerd en maakt gebruik van een geïntegreerde koppeling om torsietrillingen te dempen en foutieve uitlijning te compenseren.

De uitgang is een SAE-model vliegwiel en behuizing die wordt aangesloten op SAE-aangedreven apparatuur zoals marinetandwielen of PTO's zoals de HFO/HFR (olie-/luchtaangedreven PTO), KPTO (vloeistofkoppeling) en PF-PTO (PTO met RBD-rubberkoppeling) van Transfluid of elk ander type SAE-transmissie.

De units worden zelfstandig aangedreven met hun eigen smeercircuit.

Er zijn ontwerpen met voetuitvoering beschikbaar. Bij installatie aan de uitgangszijde van apparaten met een elastische koppeling, vereist Transfluid hierover volledig informatie om de torsionele compatibiliteit van het systeem te controleren.

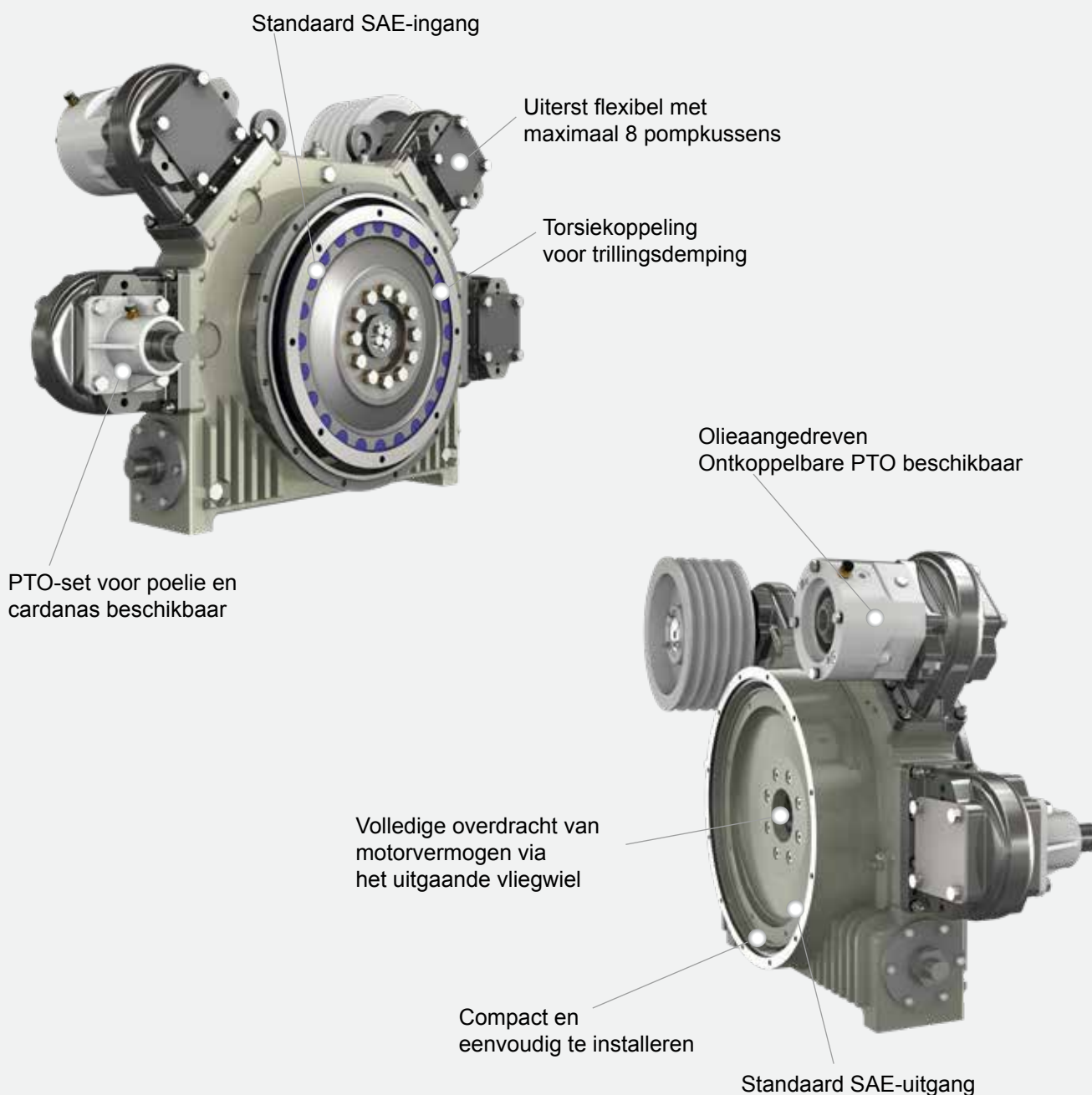

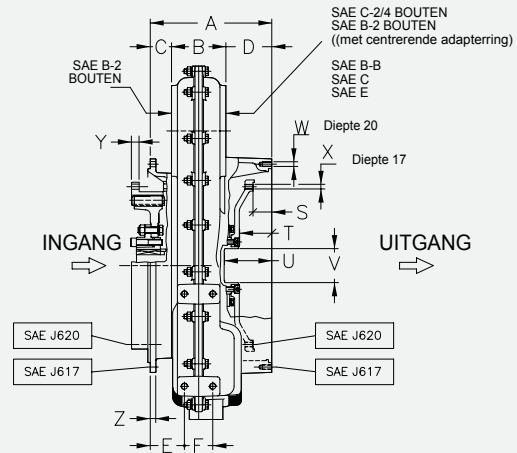
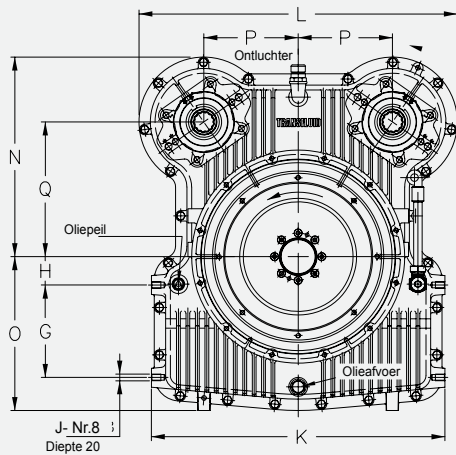

MPD14

AFMETINGEN																														
Grootte	INGANG		UITGANG		A	B	C	D	E	F	G	H	J	K	L	N	O	P	Q	S	T	U	V	W		X		Y	Z	
	SAE J617	SAE J620	SAE J617	SAE J620																				Ø	Nr	Ø	Nr			
14	3	11 1/2"	3	11 1/2"	257	115	45	97	72,5	60	195	60	M14	620	673	422	325	199,2	284,5	39,6	68,1	100	72	M10	12	M10	8	52	12	
	1	14"			282																							70	97,5	

TECHNISCHE GEGEVENS							
Grootte	Gewicht zonder olie kg	Olie Hoeveelheid l	Max snelheid tpm	Max ingangskoppel Nm	Totaal Koppen kW	Enkele Kop kW	Verhouding (n1:n2)
14	195	12,5	2600	2000	175	120	1,0

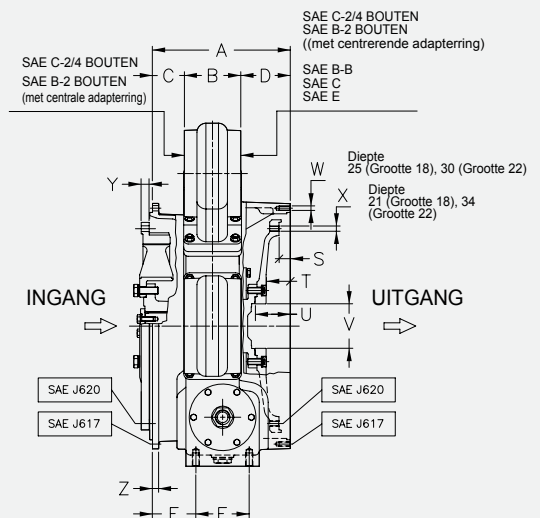
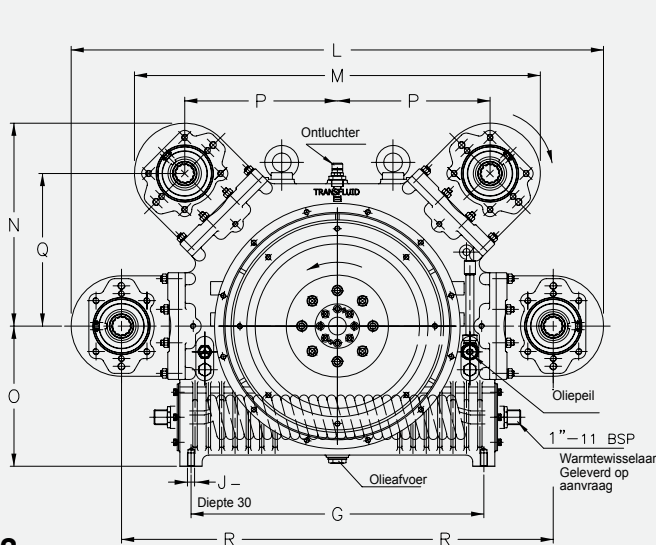

MPD18-22

AFMETINGEN																														
Grootte	INGANG		UITGANG		A	B	C	D	E	F	G	J	L	M	N	O	P	Q	R	S	T	U	V	W		X		Y	Z	
	SAE J617	SAE J620	SAE J617	SAE J620																				Ø	Nr	Ø	Nr			
18	1	14"	1	14"	310	127	71,5	111,5	97,5	120	658	M16	1197	913	456,5	315	343	343	485,2	25,4	53,5	79	100	M10	12	M12	8	18	14	
	1	14"	0	18"	374		119	128	134	130	772	M18	1326	1004	502	415	388,7	388,7	549,7	15,7	48,2	81	150	M12	16	M16	6	85	15	
22	0	18"			363		108																						18	20

TECHNISCHE GEGEVENS							
Grootte	Gewicht zonder olie kg*	Olie Hoeveelheid l	Max snelheid tpm	Max ingangskoppel Nm	Totaal Koppen kW*	Enkele Kop kW*	Verhouding (n1:n2)
18	350	18	2200	3350	300	120	1,0 (0,88)
22	530	35	2100	6300	400	175	0,95

* trek 20 kg af voor elke kop

** @ max. snelheid

*** geen SAE-standaard

Afmetingen kunnen zonder voorafgaande melding wijzigen

SPD - DUBBELE POMPAANDRIJVING

De SPD is een modulaire gesplitste aandrijflijn die is ontworpen voor montage op industriële motoren met SAE-vliegwiel en behuizingen.

De ingang is een ruwe vliegwielkoppeling met rubberen blokaandrijving. Deze elastische koppeling absorbeert radiale en angulaire foutieve uitlijningen en dempt torsietrillingen.

De SPD-uitgang is een SAE A of B-pomptoren met dubbel kussen of SAE-vliegwiel en vliegwielbehuizing. Voor eenvoudige installatie kan de pomptoren op 12 mogelijke posities over 360 graden worden gemonteerd. Het uitgangsvliegwiel kan transmissies, pompen, compressoren en PTO's aanvaarden.

SPD 11

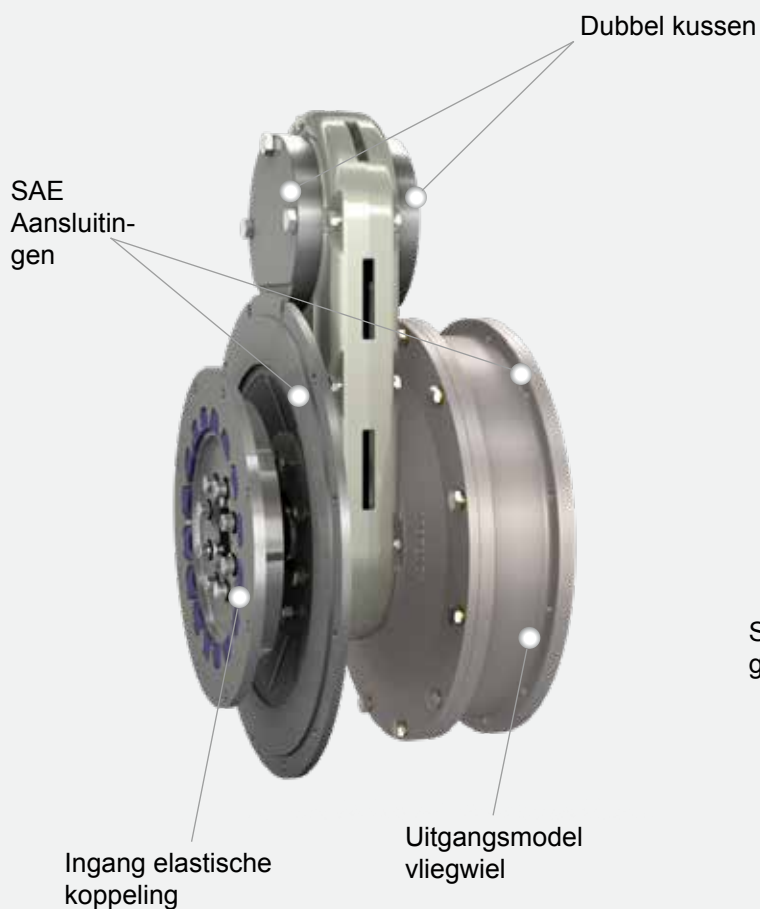

SPD 12

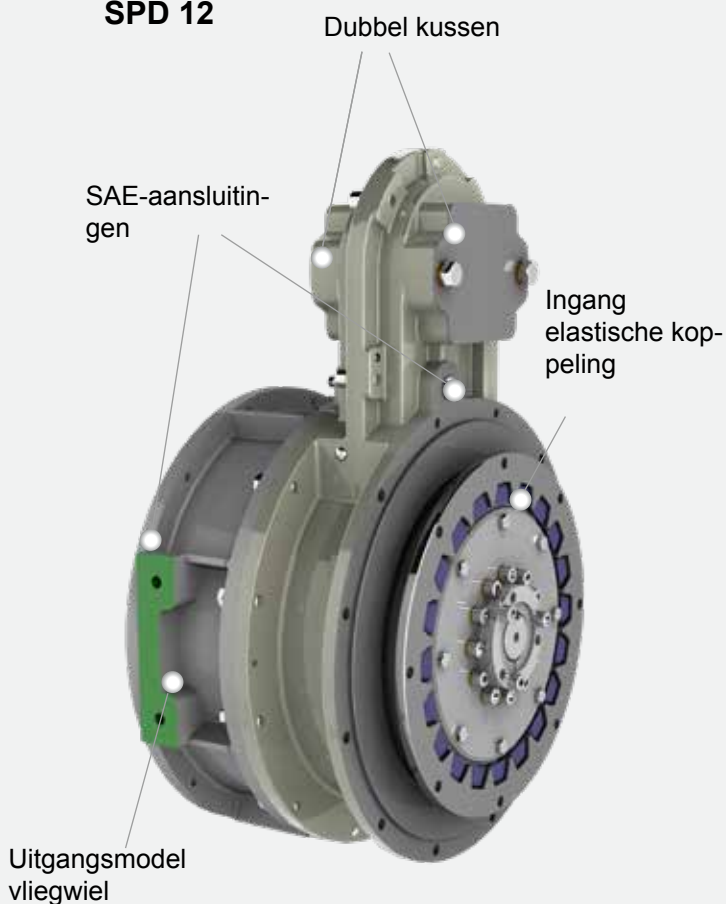

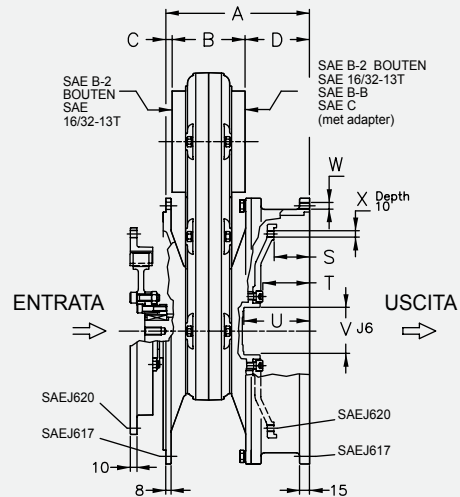
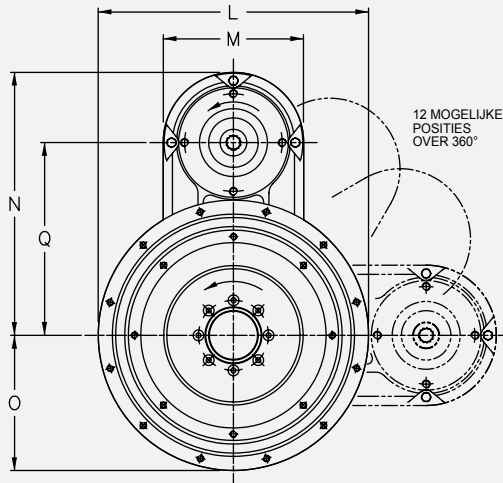

SPD 11

AFMETINGEN																		
Grootte	INGANG		UITGANG		A	B	C	D	L			M	N	O			Q	S
	SAE J617	SAE J620	SAE J617	SAE J620					SAE 3	SAE 4	SAE 5			SAE 3	SAE 4	SAE 5		
11	3 4 5	11½ 10" 7½	4	10	218,5	111	9,5	98	451	404	356	210	393	225,5	202	178	288	53,8

AFMETINGEN								TECHNISCHE GEGEVENS							
Grootte	T	U	V	W		Y		Gewicht kg	Max snelheid tpm	Max ingangskoppel Nm			Kop kW*	Verhoudingen (n1:n2)	
				Ø	Nr	Ø	Nr			SAE 3	SAE 4	SAE 5			
11	71	100	72	M10	12	M10	8	50	3000	560	560	310	53	1,0	

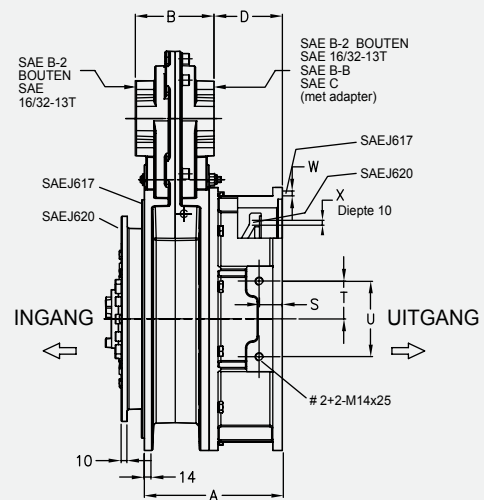
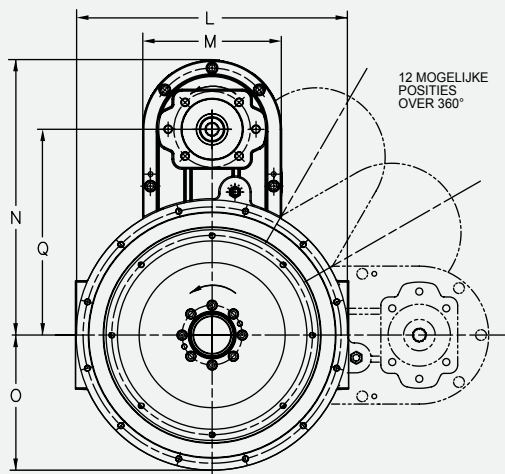

SPD 12

AFMETINGEN																		
Grootte	INGANG		UITGANG		A	B	D	L	M	N	O	Q	S	T	U	W		
	SAE J617	SAE J620	SAE J617	SAE J620												Ø	Nr	
12	3 4	11½ 10"	3 4	11½ 10"	237 247	134	117 127	454	231	460	226	344	40 50	65	130	M10	12	

TECHNISCHE GEGEVENS								
Grootte	X		Gewicht kg	Max snelheid tpm	Max ingangskoppel Nm		Kop kW*	Verhoudingen (n1:n2)
	Ø	Nr			SAE 3	SAE 4		
12	M10	8	73	3000	860	560	120	0,93

* @ 3000 tpm

Afmetingen kunnen zonder voorafgaande melding wijzigen

Hoofduitbreiding voor MPD18 en 22 alleen

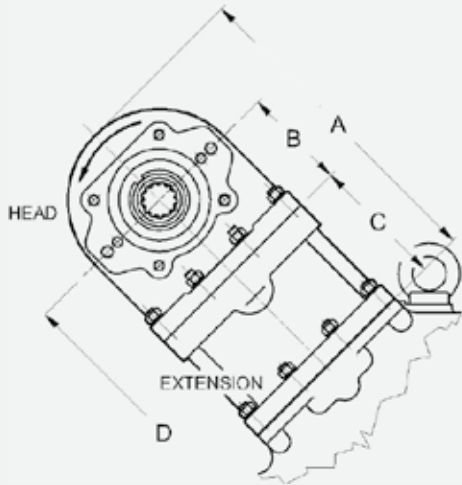

AFMETINGEN				
	A	B	C	D*
MPD18	405	128	164	649
MPD22	431	128	190	740

*van hoofdas

Wanneer er interferentie is tussen de pompen die op de MPD gemonteerd zijn, en het aangedreven apparaat, is de uitbreidingsset de perfecte oplossing. Deze set kan op elke kop worden gemonteerd en voorziet 164 mm extra speling voor MPD18 en 190 mm voor MPD22. Bovendien draait de uitbreidingsset de draaiing van de MPD-kop om, dit is handig wanneer motordraaiing nodig is.

Lucht-/olieaangedreven koppelingen voor ont koppeling pomp

BB640

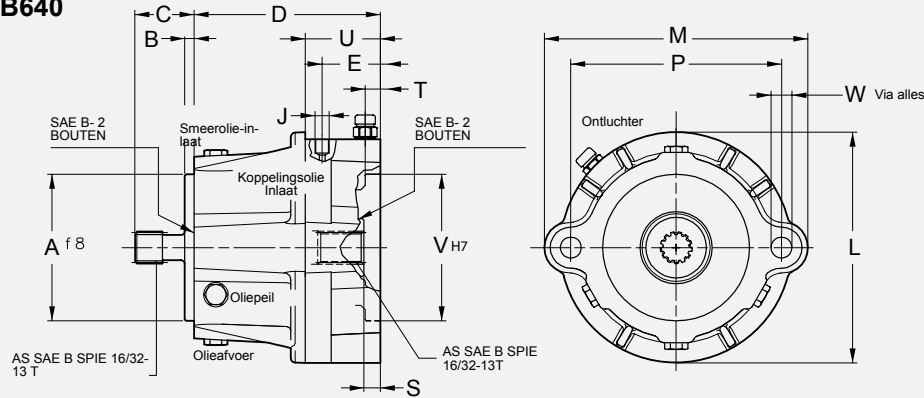

CC650

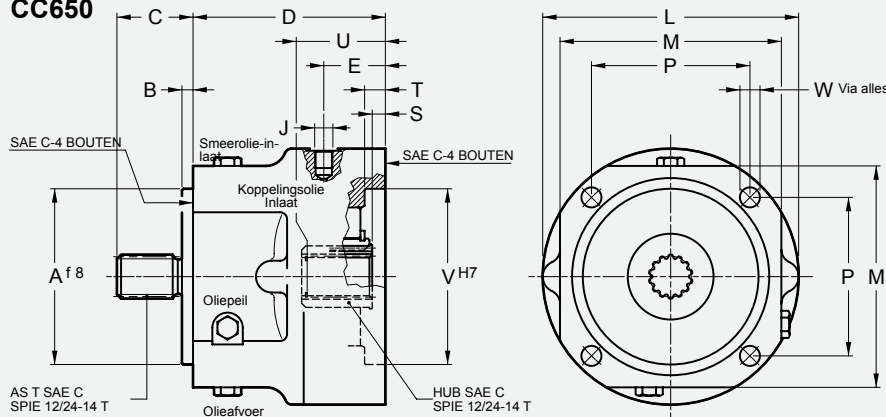

BB640	Werkdruk bar	5	7	9
	Max koppel Nm	140	195	250
CC650	Werkdruk bar	5	7	9
	Max koppel Nm	280	390	500

Grootte	AFMETINGEN														TECHNISCHE GEGEVENS				
	A	B	C	D	E	J	L	M	P	S	T	U	V	W		Max koppel Nm	Max druk bar	Gewicht zonder olie kg	Olie Hoeveelheid l
	Dia.		Nr																
BB640	101,6	6,5	41	129	41,5	1/8" BSP	168	190	146	11,5	10,5	52	101,6	14,5	2	340	12	15	1,6
CC650	127	8	55	139	44,5	1/4" BSP	185	160	114,5	9,5	15	56,5	127	14,5	4	830	15	16,5	1,8

Afmetingen kunnen zonder voorafgaande melding wijzigen

Hoofd-PTO voor in-line en poeliemontage

TECHNISCHE GEGEVENS					
PTO	Max snelheid tpm	Max koppel Nm	Max zijbelasting N met X=24	Gewicht zonder olie kg	Olie Hoeveelheid l
SAE B	3000	140	3000	6	0,05
SAE C	3000	500	7200	7	0,05

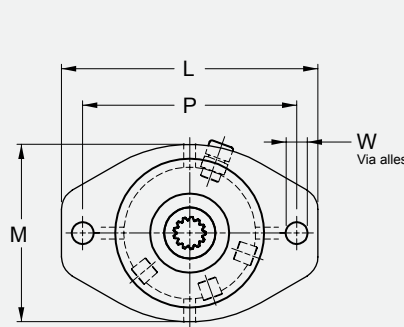
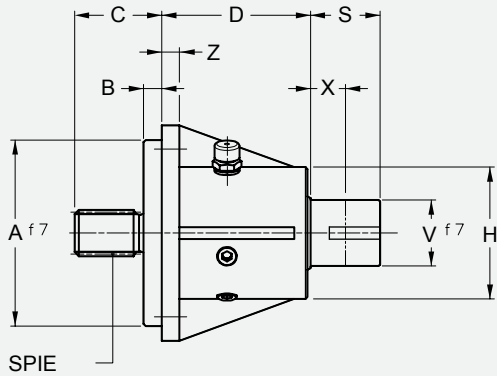

SAE B - 2 GATEN

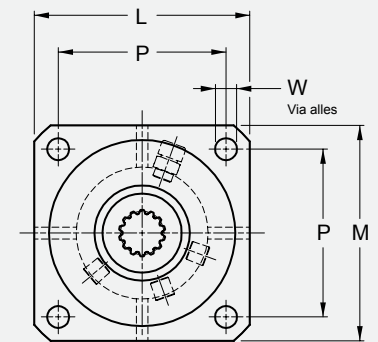

SAE C - 4 GATEN

AFMETINGEN														
PTO	SPIE SAE J744	A	B	C	D	H	L	M	P	S	V	W		Z
												Dia.	Nr	
SAE B	13T 16/32	101,6	9	41	101,5	90	175	121	146	47,5	45	15	2	12
SAE C	14T 12/24	127	12,5	55	101,5	90	147	147	114,5	47,5	45	15	4	12

SU vrijstaand
(zonder pilotlager)



SU4 - SU3

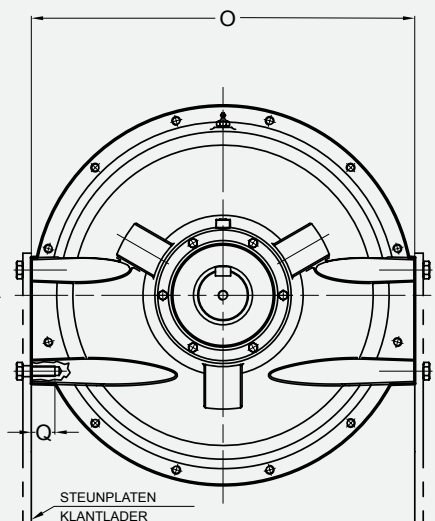
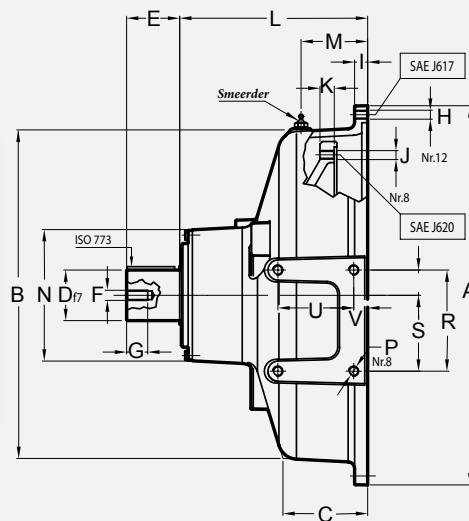

SU1

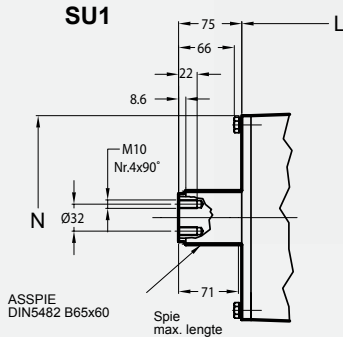

ASSPIE DIN5482 B65x60

AFMETINGEN																									
Grootte	SAE J617	SAE J620	A	B	C	D	E	F	G	H	I	J	K	L	M	N	O	P	Q	R	S	T	U	V	kg
SU4	4	10"	403	350	105	42	48	M12	25	M10	15	M10	-	201,5	-	138	405	M10	28	105	80	25	85	15	35
SU3	3	11½"	450	390	100	60	63	M12	25	M10	15,5	M10	78	223	78	156	455	M12	28	120	90	30	90	16,5	52
SU1	1	14"	552	500	143	Zie tekening				M10	23	M10	96	251	120	242	555	M16	35	240	120	120	130	25	115

Afmetingen kunnen zonder voorafgaande melding wijzigen

MPD met HFO OLIEAANGEDREVEN PTO



SPD met HFR OLIE-/LUCHTAANGEDREVEN PTO



MPD met KPTO VARIABELE VULLING VLOEISTOFKOPPELING



MPD met RANGERMATIC POWER SHIFT TRANSMISSIE



MPD met MARINEVERSNELLING



MPD met INGANG en UITGANG CARDANAS (VOETMONTAGE)

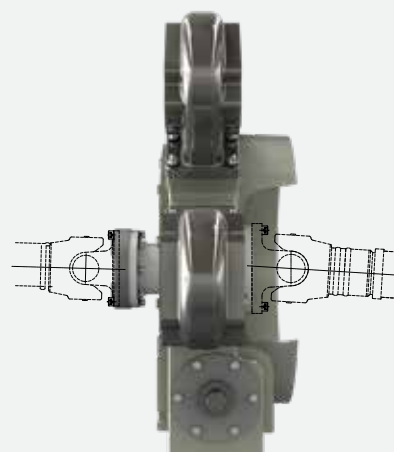

CHINA
 TRANSFLUID BEIJING
 TRADE CO. LTD Beijing
 Tel.: +86.10.60442301-2
 tbtinfo@transfluid.cn

FRANKRIJK
 TRANSFLUID FRANCE s.a.r.l.
 38110 Rochetoirin
 Tel.: +33.9.75635310
 tffrance@transfluid.eu

NEDERLAND
 TRANSFLUID NORTH EUROPE B.V.
 NL-3992 AK, Houten
 Tel. +31 (0)85 4868530
 info@bellmarine.nl

RUSLAND
 TRANSFLUID OOO
 Moscow
 Tel. +7.495.7782042
 tfrussia@transfluid.eu

VERENIGDE STATEN
 TRANSFLUID LLC
 Auburn, GA 30011
 Tel.: +1.770.8221,777
 tfusa@transfluid.us

Wereldwijde website: www.transfluid.eu • E-commerce website: www.buy-transfluid.com

TRANSFLUID S.p.A. • Via Guido Rossa, 4 • 21013 Gallarate (VA) Italy • T. +39 0331 28421 • info@transfluid.eu